



A Review on: Automatic LPG Cylinder Booking and Leakage Detection using Arduino UNO

Ashutosh N. Ganorkar¹, Semkant R. Pahune², Abhishek K. Damedhar³, Jitendra Waghmare⁴
BE Student^{1, 2, 3}, Assistant Professor⁴

Department of Electronics and Telecommunication
Nagpur Institute of Technology, Nagpur, India

Abstract:

LPG cylinders have become an integral part of every home. Our kitchens are occupied with LPG cylinders which help us make delicious food. But it can be dangerous and life threatening. Therefore, it requires constant vigilance to reduce the danger. The aim of this project is to design a safety-oriented system which will alert the user about any threat in the kitchen through mobile and also capable of performing required action immediately. This system will detect leakage of LPG and send an alert message to the user, at the same time it will switch off the gas supply of LPG by switching regulator-switch using BO motor. It ensures safety from any gas leakage accident like suffocation and explosion. As an additional advantage, this system has a weighing sensor which can measure the weight of the cylinder and regularly update user about gas left in the cylinder. This system will also help customers to know whether they are being cheated by gas agency by providing less amount of LPG. In the present time, everyone is busy in their daily life and it is difficult to know the status of the gas cylinder. Further, it will register your booking through GSM technology by sending SMS to the distributor company and also send an alert to user at the same time. It will be helpful for those aged people who live alone and are dependent on others, by making them independent and secure them from any kitchen hazardous.

Keywords: Arduino, Load cell, LPG booking, GSM module, Gas leakage, MQ-6 sensor, BO motor.

I. INTRODUCTION

In India, the supply of LPG through pipelines is not possible due to shortage of LPG. As technology being improved many gas agencies or distributors have implemented IVRS these days although due to daily busy schedules, customer finds very difficult to book new cylinder, and also it is very dangerous when a LPG gas leakage occurs in any domestic usage, chemical industry or in any other applications. This project provides automatic booking of LPG cylinder and to overcome the problem of LPG leakage. So, our proposal is to completely automate the process of refill booking without human intervention that accordingly will help consumer against foul play. Our system is also intended to help consumers to upgrade their safety standards, act in accordance with statutory requirements on environmental commitments and most importantly the basic function being prevented by accidents and protect life and property from disasters. The primary objective of our paper is to measure the gas present in the cylinder when weight of the cylinder reached below the fixed load, using the pervasive sensors. The gas retailer gets the order for a new cylinder and the house owner receives the message about the same and the details about the booking proceedings. And the secondary objective is to provide any malfunction in gas system in order to prevent damage or explosion of LPG.

II. LITERATURE SURVEY

IoT based technique [1] => The gas booking/order is being done with the help of IOT and that the continuous weight measurement is done using a load cell which intern works on the principle of piezo electric sensor is interfaced with a Microcontroller, i.e. when a gas container is placed on the

load cell it measures the weight and sends an electric pulse to the microcontroller which will compare the pulse with an ideal value in form of digital (the electric pulse is converted in to equivalent digital value). If the compared output is high then it sends a pulse(high) to the IoT which will update it to the internet but doesn't place an order, but if the compared output is low then it send a pulse (low) to the IoT which will update it to the internet an even place a gas refill order. For ease of user there is even Radio Frequency (100m) module which has its Tx encoder kit to the main board & its Rx decoder for a sub board, so the need of providing it with these is that when a gas order is being place it notifies the consumer with a siren alarm. When it comes to security of the kit as well as gas container we have an MQ-2 (gas sensor), LM 35 (temperature sensor), which will detect the surrounding environment for any chance of error. Whenever any change is subjected in any of the sensors (load cell, LM35, MQ-2) a siren (60db) is triggered.

ARM Controller based technique [2]=> to design Automatic LPG gas booking and leakage detection system for use in Home and Industry. Such a monitoring system will be used to automatically LPG gas booking and Leakage detection. Here we can use the mechanical instrument like weight stand (load cell) for measuring the gas cylinder level. When the gas level reaches below to the threshold level which set value in the system. The load cell output is in few mV, so these outputs provide to the amplifier through the ARM LPC 2138 controller and automatically booked the cylinder using a GSM module using SMS service and display the information on LCD. MQ-6 gas sensor is used in system, When the LPG leakage is detected by the sensor and information is sent to the user by short message service (SMS) and simultaneously alerts the customer using GSM

module, display on LCD, buzzer will get ON and exhausts fan use to clean area.

PIC Controller based technique [3] => This system will detect leakage of LPG; on the detection of gas leakage, microcontroller receives commands from gas leakage sensor, and send an alert message to the user, at the same time it will switch off the mains power supply using relay and a mechanical design attached with it will switch off regulator by rotating motor about 60°. Microcontroller is used to perform all these functions, which activates all the modules on required situation. It ensures safety from any gas leakage accident like suffocation and explosion. As an additional advantage, this system has a weighing sensor which is specially designed for weighing cylinder can measure the weight of the cylinder and regularly update user about gas left in the cylinder. This system will also help customers to know whether they are being cheated by gas agency by providing less amount of LPG. In the present time, everyone is busy in their daily life and it is difficult to know the status of the gas cylinder. Further, it will register your booking through GSM technology by sending SMS to the distributor company and also send an alert to user at the same time. It will be helpful for those aged people who live alone and are dependent on others, by making them independent and secure them from any kitchen hazardous.

Computer based technique [5] => the system's detection procedure happens through the aid of five sensors especially designed for the application needed. For the detection of temperature, an LM35 temperature sensor is used while four MQ5 sensor modules are responsible for detecting LPG concentration in the controlled environment. Notification happens through SMS services and internet notification. The GSM module block is in charge of processing the data coming from the computer when the sensors start to detect a presence of gas in the environment. This data then is passed to the GSM/GPRS module which utilizes SIM900D cellular engine and passes the message to the mobile user assigned. The internet notification, on the other hand, involves no additional physical hardware on the user end side. However, there are connections which cannot be seen physically like the connection between the computer program and the database which is physically stored at the server of the webhosting company, Microsoft Azure. The webhost then gets the desired data from the server's database and allows it to be uploaded directly in the assigned website. The execution of actions in diffusing the concentration of LPG and stopping it right from its source happen through the use of an exhaust fan and a solenoid valve.

III. PROPOSED APPROACH

- A. Automatic LPG cylinder booking
- B. Gas leakage detection

A. In automatic gas cylinder booking we continuously measure the amount of gas present in the cylinder using load cell which is interfaced with Arduino UNO and displaying weight of cylinder on LCD display. When gas level goes below the set level then message will be send to the gas agency and notification about same is given to the user using GSM module. So, user get cylinder within time.

B. In gas leakage detection process, any gas leakage is checked by gas sensor (MQ-6) which is interfaced with Arduino UNO. When leakage is detected BO (battery operated) motor will be immediately turn off the gas

regulator-switch at the same time it informs the user about the gas leakage by sending the SMS, turning on the buzzer and also displaying message on LCD.

IV. HARDWARE DESCRIPTION

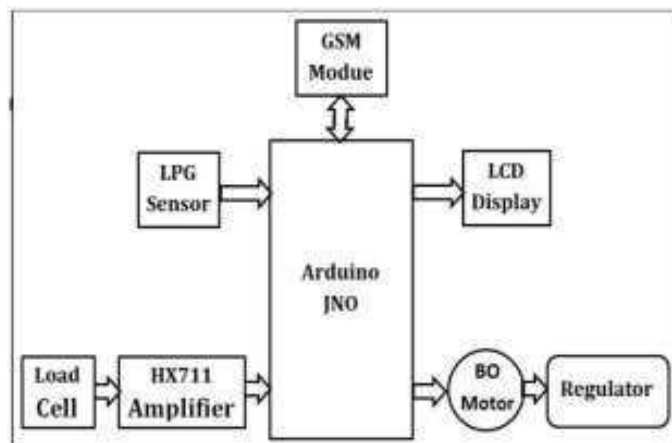

Figure.1. Block diagram representation of the system

Arduino UNO: The Arduino UNO is a microcontroller board based on the ATmega328. It uses an ATmega16U2 faster transfer rates and more memory. Arduino can be used to develop stand-alone interactive objects or can be connected to software on your computer. It uses Arduino IDE (Integrated Development Environment) software which allows you to write programs and upload them to your board. A program written with the IDE for Arduino is called a sketch.

Features:

- a) Input voltage: 7-12V
- b) 14 Digital I/O Pins (6 PWM outputs)
- c) 6 Analog Inputs
- d) 32k Flash Memory
- e) 16Mhz Clock Speed

Load cell (YZC-1B): A load cell is a transducer that can translate pressure (force) into an electrical signal. Mostly strain gauge type load cell is used. In a strain gauge load cell, the force is being sensed by the deformation of a strain gauges on the element.

Features:

- a) Capacity: 3-200kg
- b) Material: Aluminium-alloy or alloy steel
- c) Type: Parallel beam type

HX711 Amplifier: The HX711 load cell amplifier is used to get measurable data out from a load cell and strain gauge. The HX711 Load Cell Amplifier accepts five wires from the load cell. These pins are labelled with colours: RED, BLK, WHT, GRN, and YLW. Where red, black, green and white wires come from the strain gauge on the load cell and yellow is an optional ground wire. The four wires coming out from the load cell are usually: VCC is red, Ground is black. Output signal is white, green or yellow. Once the load cell is hooked up to the amplifier, you can hook up VDD, VCC, DAT, CLK, and GND to a microcontroller.

GSM Module (SIM900A): GSM module is used to establish communication between a controller and a GSM-GPRS system. It requires a SIM card just like mobile phones to activate communication with the network. Also, they have IMEI number similar to mobile phones for their identification.

Features:

- a) Dual-Band 900/1800 MHz
- b) Control via AT commands
- c) Operation temperature: -40° C to +85° C

- d) Supply voltage range: 3.2V to 4.8V
- e) Low power consumption: 1.0mA

LPG Sensor (MQ-6): The MQ-6 is a semiconductor gas sensor that detects the presence of LPG, Isobutane, and Propane gas. The sensor can operate at temperatures from -10 to 50°C and consumes less than 150 mA at 5V.

Features:

- a) High Sensitivity to LPG, Iso-butane, propane.
- b) Small sensitivity to alcohol, smoke
- c) Detection Range: 100 - 10,000 ppm
- d) Fast Response Time: <10s

BO motor: BO (Battery Operated) light weight DC geared motor which gives good torque and rpm at lower voltages. It can do reverse and forward directions.

Features:

- a) Working voltage: 3-12V
- b) No load speed: 200rpm
- c) No load current: 125mA
- d) Torque: 500gf.cm

Motor Driver IC (L293D): L293D is a dual H-bridge motor driver integrated circuit (IC). Motor drivers act as current amplifiers since they take a low-current control signal and provide a higher-current signal. Input logic 00 or 11 will stop the corresponding motor. Logic 01 and 10 will rotate it in clockwise and anticlockwise directions, respectively. Enable pins 1 and 9 (corresponding to the two motors) must be high for motors to start operating.

LCD display: Here we use a 16×2 LCD display for displaying the status of the cylinder i.e. leakage of gas if occurred and weight of the cylinder continuously.

Buzzer: Buzzer is use to indicate that gas leakage has occurred.

IV. REFERENCES

- [1]. Kumar Keshamon, Sabbani Hemanth, “Smart Gas Level Monitoring, Booking & Gas Leakage Detector over IoT”, 2017 IEEE 7th International Advance Computing Conference.
- [2]. Saurabh Joshi, Rohit Patil, “Automatic System for LPG Refill Booking and Leakage Detection”, Vol-3 Issue-2 2017 IJARIII- ISSN(O)-2395-4396.
- [3]. Ajay Kumar, Mukesh Kumar, Balwinder Singh, “Designing and Implementaion of Smart LPG Trolley with Home Safety”, 2016 2nd International Conference on Next Generation Computing Technologies (NGCT-2016) Dehradun
- [4]. M.S. Kasar, Rupali Dhaygude, Snehal Godse, Sneha Gurgule, “Automatic LPG Gas Booking and Detection System”, International Journal of Advanced Research in Electrical, Electronics and Instrumentation Engineering Vol. 5, Issue 3, March 2016.
- [5]. Kenneth V. Balmes, James Matthew T. Chua, Mary Anne O. De Jesus, and Karen Cristine O. Tan, Argel A. Bandala, “Utilization of Sensor Network for Combustible Gas Detection and Monitoring Implemented in House Hold”, IEEE Conference 2015.