



Smart Stick for Blind using Arduino, Ultrasonic Sensor and Android

Hardik R. Shah¹, Dhiraj B. Uchil², Sanveg S. Rane³, Prasanna Shete⁴
 B.E. Student^{1,2,3}, Assistant Professor⁴
 Department of Computer Engineering
 K.J. Somaiya College of Engineering, Mumbai, India

Abstract:

The term blindness is used for complete or nearly complete vision loss. Blind people need some help while travelling to feel safe. In this paper, we have developed a smart stick which increases the accessibility of blind person to move around and voice output is given when obstacle is or pothole is detected. This smart stick is cheap, lightweight and fast. The stick consists of 3 ultrasonic sensors for obstacle detection and 1 ultrasonic sensor for pothole detection. The android application is linked with ultrasonic sensors for notification of obstacle and pothole. The application also consists of real time navigation system with speech recognized destination, automatic launch and Gesture detection with speed dial, emergency alarm etc.

Keywords: Blind people, GPS (Global Positioning System) navigation, Ultrasonic Sensors, Arduino, Gestures.

I. INTRODUCTION

As of 2012, there were nearly 285 million people who were visually impaired of which 246 million had low vision and nearly 39 million were blind. Blind people often have problems while moving around in an environment where they are not familiar. They use the traditional white cane. This cane detects obstacle only when they touch it and hence prior detection of obstacle is problem.

The cane also cannot properly detect obstacle which are at certain height. Thus, blind people will feel confident to move around only when obstacles are known from far distance. This can be done with help of Ultrasonic sensors. There are various types of technologies and sensors available but ultrasonic sensors are chosen because they are cheap and light weight and can detect obstacle up to 400cm. There is also a possibility that blind person might not know the route or might have some emergency. These problems can be taken care with real time navigation and gesture recognition. Smart stick will help the blind person in easy mobility just like normal person.

A. Abbreviations and Acronyms

ETA–Electronic Travel Aid, GPS- Global Positioning System.

II. PROBLEMS WITH EXISTING SYSTEM

An Electronic Travel Aid is form of Assistive technology for enhancing mobility of blind person. The research problem of designing a better ETA is tough one. Blind people find travelling difficult because they cannot determine where obstacles are. This process is also called as ‘Spatial Sensing’. There are various problems with existing system. First, the rangefinder technology is unreliable in detecting steps. Second, Blind people find various sound pitches and vibrations difficult to understand. Third, these systems are quite expensive and since blind person have to depend financially on someone, they don’t feel worth to invest so much. Problems and various existing systems:

1. Walkmate – Developed in 1993. It had detection only upto 1.83m.

2. Miniguide US- Developed in 2004. The price was \$545 which is quite expensive.

3. Laser cane- The latest one is named as ‘N2000’. It provides 3 beams straight, overhead and for downward drops. It is still available and is priced at \$2650. The developed smart stick has range of 400 cm and it costs less than 35\$.

III. PROPOSED SYSTEM

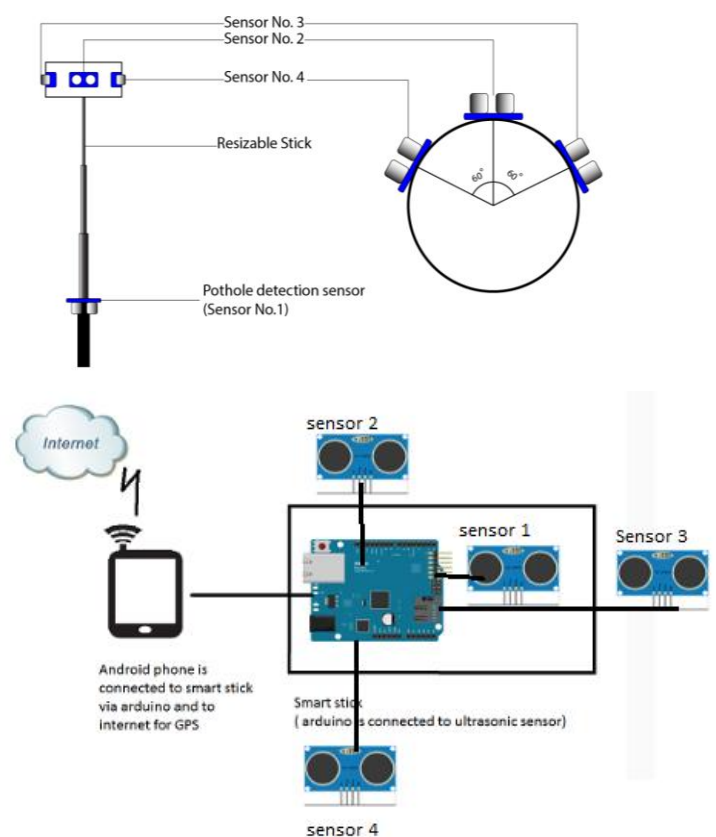

Figure.1.Proposed System

The above two Fig. shows the architectural diagram of the system. The system consists of stick on which 3 ultrasonic

sensors are placed (sensor 2, 3 and 4). These sensors are used for obstacle detection. Range of each sensor is 400 cm front and 60 degrees wide. Hence these, sensors are placed in such manner that covers most of the obstacles.

At the bottom of stick it consists of another ultrasonic sensor (sensor 1) which is used for pothole detection. The entire stick is variable in length according to height of the user. All the ultrasonic sensors are connected to the arduino.

The arduino is connected to the mobile which consists of android application. The application is used for obstacle and pothole notification through voice, real time GPS navigation system and gesture detection.

The entire project is divided into several parts:

- a) Obstacle detection
- b) Pothole detection
- c) Android application

IV. METHODOLOGY

A. Obstacle Detection

The three sensors placed on the top of the stick are used for obstacle detection. Each sensor senses the obstacle towards the front using time required to receive the signal and then distance is calculated in the arduino using distance formula.

The algorithm used for obstacle detection is:

Step 1: dist_front = distance received from sensor 2 or front sensor.

Step 2: if (dist_front >= 100 && dist_front <= 200)
 alert that obstacle is ahead.
 Go to step 5

Step 3: calculate dist_right and dist_left i.e. distance from right and left sensor respectively.

Step 4: if dist_right < 100 && dist_left > 100
 alert Turn left
 else if dist_left < 100 && dist_right > 100
 alert Turn right
 else if dist_left < 100 && dist_right < 100
 alert Path is blocked
 else alert Turn anywhere
 go to step 1

Step 5: check dist_front again for closeness

step 6: if (dist_front < 100)
 alert obstacle is very close in front
 go to step 3

This output is send to android application using specific characters assigned to each direction. Using text to speech in android, the output is given in form of voice.

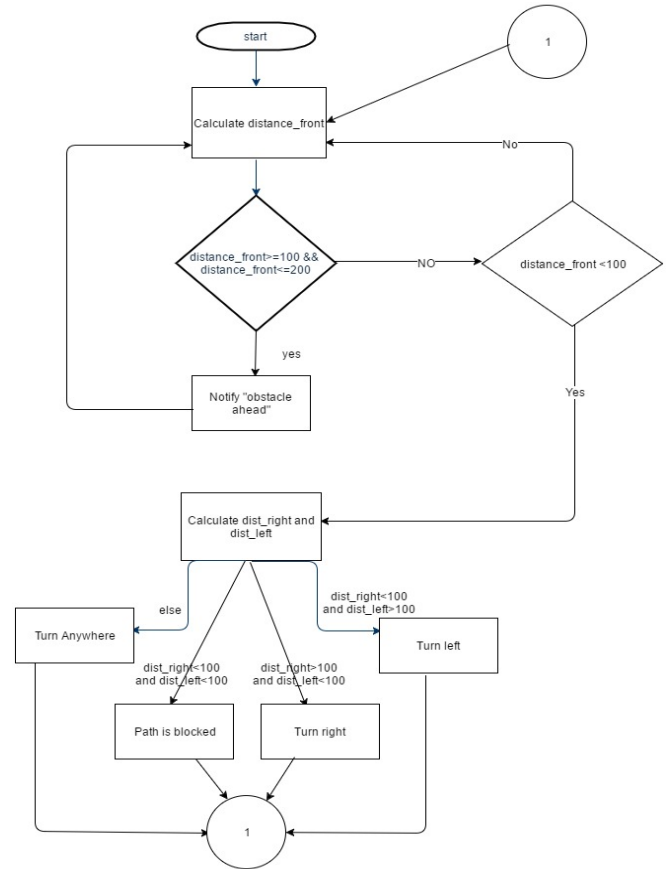

B. Pothole Detection

The pothole sensor attached at the bottom of the stick, facing towards ground, sends reading of the time required for the ultrasonic waves to reflect back from the ground; which is then converted to distance using the distance formula.

Speed of sound in air = 340 m/s
 Distance = (speed * time) / 2
 Distance is divided by 2 is done because initial distance received is for sending signal plus receiving signal.

Initially values are used to calculate the threshold value and later each distance value calculated is compared with the threshold to check for pothole. Pothole detection detects a pothole on user's path by comparing each new value with the calculated threshold value. Pothole detection calculates a threshold value by measuring the stick user's patterns of using the stick (since each person's height is different and stick's holding point is also different), which is then used for detecting a pothole on the user's path. Initial ten values are used for calibration of the threshold value for pothole detection. The value within certain limit is considered for calibration as user's misjudgments might lead to ambiguous results. The valid results are then summed to calculate their average value and the largest value in the set is also recorded. The average value is an indicator of the height to which the user generally lifts the stick while commuting, whereas the highest value is the maximum deviation from the average during the calibration. The difference between average and the maximum value gives a maximum fluctuation value, which then is doubled and added to the average to calculate threshold i.e. error is also considered. This approach increases the accuracy of the threshold and provides the arduino with a value indicating the maximum possible distance from the ground.

$avg_value = (\text{sum of 10 values})/10.$
 $max_value = \text{maximum of initial 10 values.}$
 $fluct_value = max_value - avg_value.$
 $Threshold = 2 * fluct_value + avg$

The arduino calculates distance from ground with each loop, using the readings from the ultrasonic sensor, and compares the new value with threshold value calculated previously to check for potholes. A value greater than the threshold value indicates the possibility of presence of a pothole ahead of the user and the arduino sends a value to the android application to warn the user.

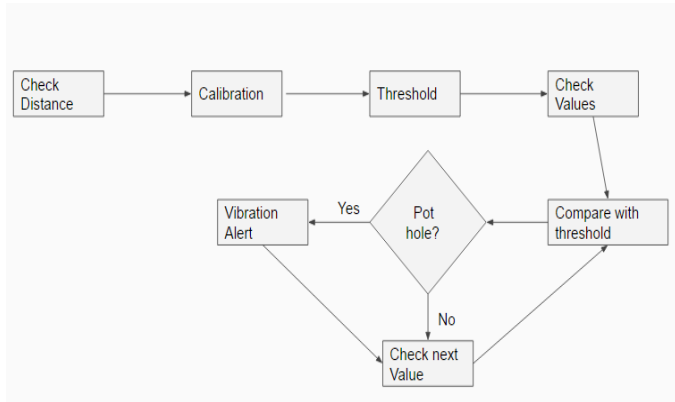

C. Android Application

The android application is used to alert the user about the various signals received from the sensors and also provides other functionalities. When a pothole or an obstacle is detected the app uses text to speech to speak out the alert to the user. It tells the user the position of the obstacle (front, left or right). The user can also start navigation from his current location by double tapping the screen.

Double tapping launches the speech to text service, the user has to speak out the name of his destination and the navigation will be started. Swiping left or right on bottom of screen launches gesture recognition. Since the person is blind, just sliding finger in particular pattern will recognize number using gesture recognition. Each number is assigned to call specific number.

V. RESULTS

Table 1

Table 1 shows the calculation of threshold from the starting ten values.

Initial Values (cm)	Threshold Values (cm)
13,15,17,19,20,14,16,15,14,12	24.5
12,19,21,24,13,19,15,18,15,16	30.8

Table 2

Table 2 shows the result of obstacle detection. First Column shows in which direction the obstacle is present. Second column shows the actual output of the direction of obstacle as detected by sensors. The third column shows the range at which obstacle is detected and fourth column shows how accurate the result is.

Obstacle from	Output	Range (cm)	Result
front	“obstacle ahead”	145	accurate
front	“obstacle ahead turn anywhere”	78	accurate
front and left	“turn right”	60	accurate
front and right	“turn left”	82	accurate
front, left and right	“turn right”	59	Error
front, left and right	“path blocked, turning suggested”	72	accurate

Table 3

Table 3 shows the output of pothole detection. First Column shows that pothole is present or not. Second column shows the actual output of the pothole as detected by sensor. The third column shows the distance from the ground at which pothole is detected and fourth column shows how accurate the result is.

Pothole	Output	Distance from ground	Result
pothole present	“pothole detected”	30	accurate
pothole not present	“pothole detected”	28	error
pothole not present	no output	19	accurate

Table 4

Table 4 shows result of voice navigation. First column shows the destination given by user. Second column shows whether it was converted properly from voice to text. Third column shows whether navigation was started or not.

Destination	Voice to Text destination	Navigation started?
Vidyavihar station	“vidya vihar station”	Yes
Thane station	“Thane station”	Yes

Table 5

Table 5 shows the output of gesture recognition. Column one shows what gesture is drawn by user. Column two shows what gesture is detected and column three shows whether function specific to that gesture is called or not

Gesture drawn	Gesture Detected	Function called
“0”	“0”	call emergency contact 1
“V”	“V”	call emergency contact 2
“^”	“^”	call emergency contact 3

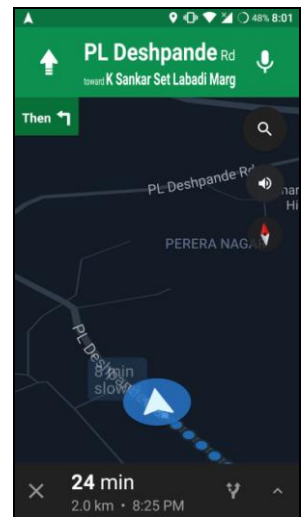
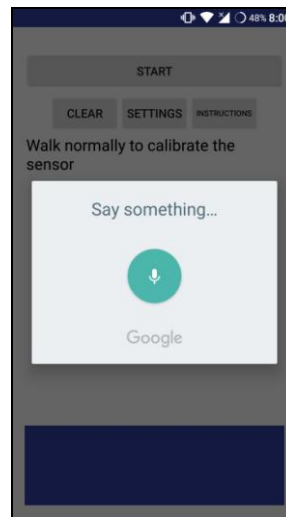

Figure.5. shows the screenshots of application for navigation.

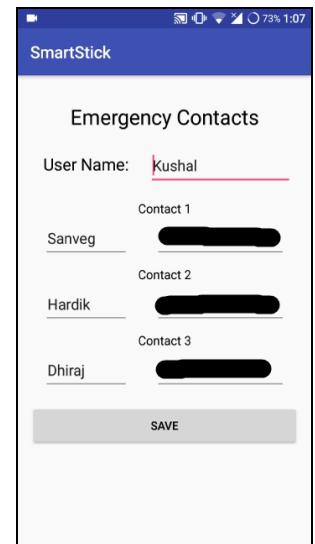
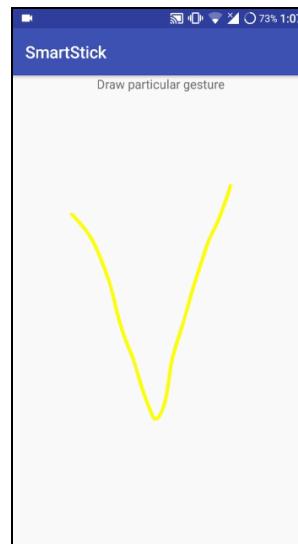

Figure.6. shows the screenshots of application for gesture detection.

VI. CONCLUSION

A. In this paper, solution was proposed to help blind people so that they can walk with confidence by detecting obstacles and potholes in their path. Solution consisted of arrangement of sensors. The horizontal sensors were able to detect obstacle whereas bottom most inclined sensor was able to detect pothole and output was provided in form of voice. Navigation and gesture recognition are also accurate enough, thereby increasing the accessibility for the blind and increasing their confidence to walk in non familiar environment

VII. REFERENCES

- [1]. M. Varghese, S. S. Manohar, K. Rodrigues, V. Kodkani and S. Pendse, "The smart guide cane: An enhanced walking cane for assisting the visually challenged," 2015 International Conference on Technologies for Sustainable Development (ICTSD), Mumbai, 2015, pp. 1-5. doi: 10.1109/ ICTSD. 2015.7095907
- [2]. D. S. Raghuvanshi, I. Dutta and R. J. Vaidya, "Design and analysis of a novel sonar-based obstacle-avoidance system for the visually impaired and unmanned systems," 2014 International Conference on Embedded Systems (ICES),



Figure.3. shows the actual implementation of stick

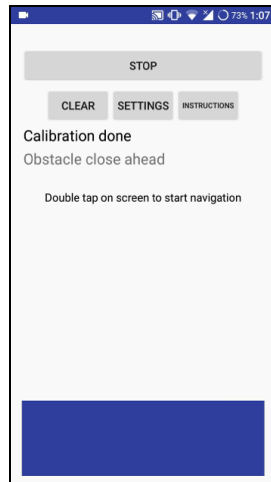
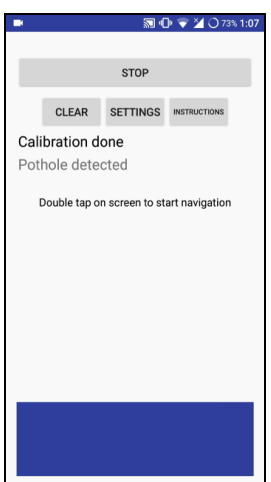
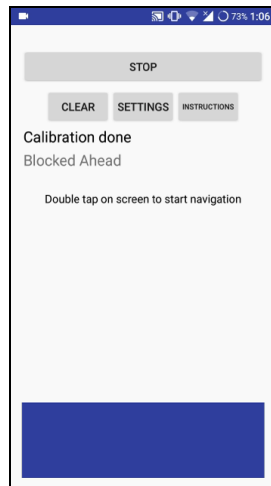
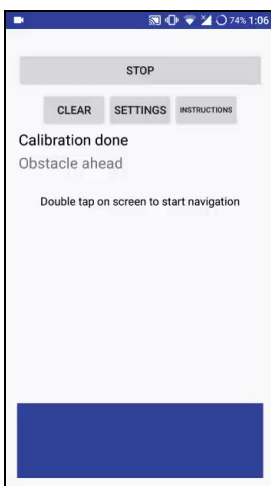

Figure.4. shows the screenshots of application for obstacle and pothole detection.

Coimbatore, 2014, pp. 238-243. doi: 10.1109/ Embedded Sys.2014.6953165

[3]. S. Gupta, I. Sharma, A. Tiwari and G. Chitranshi, "Advanced guide cane for the visually impaired people," *2015 1st International Conference on Next Generation Computing Technologies (NGCT)*, Dehradun, 2015, pp. 452-455. doi: 10.1109/NGCT.2015.7375159

[4]. A.K.Shrivastava, A.Varma and S.P.Singh "Distance measurement of an object or an obstacle by ultrasound sensors using P89C51RD2" *International Journal of Computer Theory and Engineering*, Vol.2, No.1, February 2010.

[5] Elec Freaks Ultrasonic Ranging Module HC - SR04 [Online] Available: [.http://www.micropik.com/PDF/HCSR04.pdf](http://www.micropik.com/PDF/HCSR04.pdf)

[6].Jack Loomis, Reginald Golledge and Roberta Klatzky, "Navigation System for Blind – Auditory Display Modes and Guidance", *Presence*: Vol. 7, No. 2, April 1998, pp. 193–195.

[7].Loomis JM, Klatzky RL, Golledge RG, Cincinelli JG, Pellegrino JW, Fry PA, "Nonvisual navigation by blind and sighted: Assessment of path integration ability", *J Exper Psychol General* 122(1):73–91 (1993).

[8]. H. He, and J. Liu, "The design of ultrasonic distance measurement system based on S3C2410," *Proceedings of the IEEE International conference on Intelligent Computation Technology and Automation*, Oct. 2008, pp. 44-47.

[9]. Y. Jang, S. Shin, J. W. Lee, and S. Kim, "A preliminary study for portable walking distance measurement system using ultrasonic sensors," *Proceedings of the 29th Annual IEEE International Conference of the EMBS*, France, Aug. 2007.