



# Underground Cable Fault Detection using Arduino

T.Nandhini<sup>1</sup>, J.Shalini<sup>2</sup>, T. Sai Sangeetha<sup>3</sup>, D.Gnanaprakasam<sup>4</sup>

Student<sup>1,2,3</sup>, Assistant Professor<sup>4</sup>

Department of EEE

Dr. Mahalingam College of Engineering and Technology, NPT - MCET Campus, Tamil Nadu, India

## Abstract:

The project is intended to detect the location of fault in underground cable lines from the base station to exact location in kilometers using an Arduino micro controller kit. In the urban areas, the electrical cable runs in undergrounds instead of overhead lines. Whenever the fault occurs in underground cable it is difficult to detect the exact location of the fault for process of repairing that particular cable. The proposed system finds the exact location of the fault. This system uses an Arduino microcontroller kit and a rectified power supply. Here the current sensing circuits made with a combination of resistors are interfaced to Arduino micro controller kit to help of the internal ADC device for providing digital data to the microcontroller representing the cable length in kilometers. The fault creation is made by the set of switches. The relays are controlled by the relay driver. A 16x2 LCD display connected to the microcontroller to display the information. In case of short circuit the voltage across series resistors changes accordingly, which is then fed to an ADC to develop precise digital data to a programmed Arduino micro controller kit that further displays exact fault location from base station in kilometers. Whenever a fault occurs in a cable the buzzer produce the alarm to alert and to take an immediate action by field workers.

## I. INTRODUCTION

The objective of this project is to determine the distance of underground cable fault from base station in kilometers using an Arduino board. Generally we use overhead lines. We can easily identify the faults but in rushed places or familiar cities we couldn't use overhead lines. So, we are moving to underground cables. Underground cables used largely in urban area instead of overhead lines. We can't easily identify the faults in the underground cables. This project deals with arduino microcontroller, buzzer and LCD. This proposes greatly reduces the time and operates effectively. The underground cabling system is a common practice followed in many urban areas. Many time faults occur due to construction works and other reasons. At that time it is difficult to dig out cable due to not knowing the exact location of the cable fault. arduino microcontroller, buzzer and LCD. This proposes greatly reduces the time and operates effectively. The underground cabling system is a common practice followed in many urban areas. Many time faults occur due to construction works and other reasons. At that time it is difficult to dig out cable due to not knowing the exact location of the cable fault.

## II. RELATED WORK

Programs uploaded in Arduino UNO kit to detect faults from the underground cables. When a fault occur in the underground cables, we can find out faults through Arduino controller kit. LCD display which displays the faults in Kilometre. In this project we created faults manually. Cable has many types. Every cable has different resistance which depends upon the material used. The value of the resistance is depends upon the length of the cable. In here resistance is the leading role of the project. If any deviation occurs in the resistance, the value of the voltage will be changed that particular point is called FAULT. We are finding out those faults.

## TYPES OF FAULTS

Generally there are different types of faults. Frequently occurring faults are given below

- Short Circuit Fault
- Open Circuit Fault
- Earth Fault

### Short Circuit Fault

A short circuit fault occurs when there is an insulation failure between phase conductors or between phase conductor(s) and earth or both. An insulation failure results into formation of a short circuit path that triggers a short-circuit conditions in the circuit.

### Open Circuit Fault

An open-circuit fault occurs if a circuit is interrupted by some failure. If the circuit is not closed that is called open circuit fault.

### Earth Fault

An earth fault is an inadvertent contact between an energized conductor and earth or equipment frame. The return path of the fault current is through the grounding system and any personnel or equipment that becomes part of that system.

## III PROPOSED SYSTEM

Underground fault detection deals with finding the exact fault location from the base station. Cables have some resistance. We are mainly focusing that resistance. Resistance can vary with respect to the length of the cable. If the length of the cable increases, the value of the resistance will also increase. If any

deviation occurs in the resistance value, we call that as fault point and that point can be identified with the help of arduino technology. That fault point represents the standard of distance (kilometre) from the base station and the value is displayed by the display unit.

### BLOCK DIAGRAM

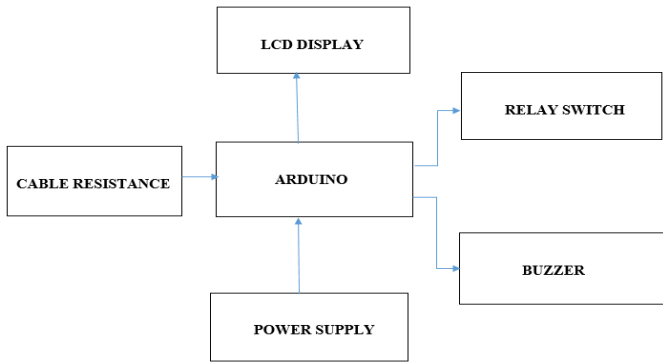

Figure.1.Block Diagram

### BLOCK DIAGRAM DESCRIPTION:

We uploaded the program in the kit. Program was written and if any fault occurs in the cable, immediately it will open the relay terminal and disconnect that faulty line only. Rest of the other lines operates normally. Arduino is the advanced version of embedded system. These Arduino has ample types but we selected Arduino UNO. It easily adapts to other devices using serial port. Relay is nothing but an electrical device that acts as a switch; if any fault occurs in the line it will disconnect the line using relay. The connector of the relay moves from normally closed conduct to normally open conduct. we can easily find the fault and disconnect the faulty line. Display unit is connected to the Arduino kit which is used to display where the fault occurs. Once faults occur in the cable, the display unit displays the exact fault location and also displays which phase is affected in the cable and how long it's affected and buzzer system is used to create an alerting signal. Buzzer systems create an alerting sound signal, once the fault occurs in the underground cable.

### SIMULATION DIAGRAM:

#### SIMULATION DIAGRAM WITHOUT FAULT

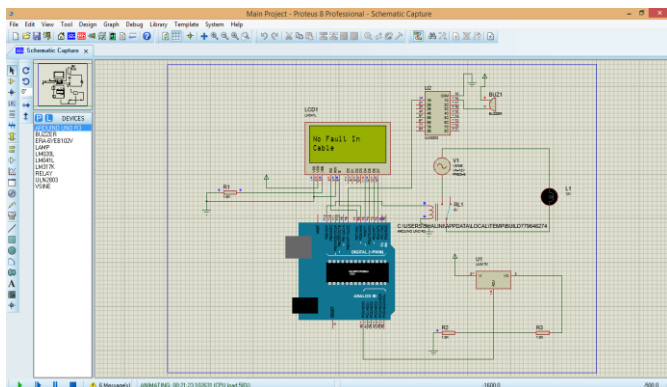

Figure.2.Simulation Diagram without Fault

### SIMULATION DIAGRAM WITH FAULT

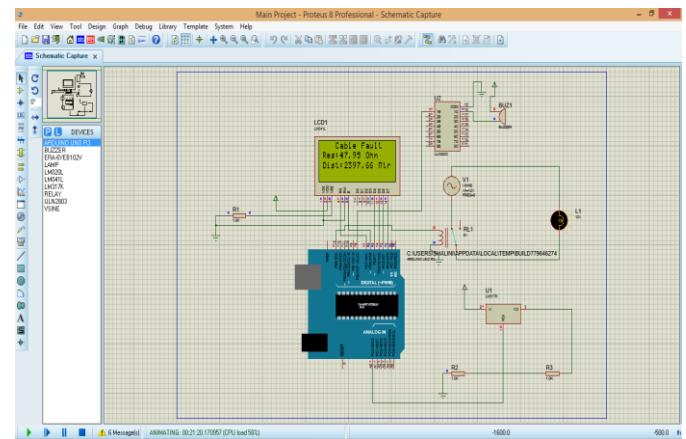

Figure.3.Simulation Diagram with Fault

### IV. SOFTWARE DESCRIPTION

#### PROTEUS SIMULATOR

Proteus is software for microprocessor simulation, schematic capture, etc. It is developed by Labcentre Electronics.

The following are the system components of proteus

- ISIS Schematic Capture – a tool for entering designs.
- PROSPICE Mixed mode SPICE simulation – industry standard SPICE3F5 simulator combined with a digital simulator.
- VSM – Virtual System Modelling lets co simulate embedded software for popular micro-controllers alongside hardware design.
- System Benefits Integrated package with common user interface and fully context sensitive help.

Proteus Virtual System Modelling combines mixed mode SPICE circuit Simulation, animated components and microprocessor models to facilitate co-simulation of complete microcontroller based designs. This is very useful and user friendly to handle the components. The version used for project design is Proteus Professional 7.0. Proteus Professional Software for automated design of electronic circuits. The package is a system of circuit simulation, based on the models of electronic components in PSpice. A distinctive feature of the package Proteus Professional is the possibility of modelling of the programmable devices: Microcontrollers, Microprocessor, DSP and others. Additionally, the package of Proteus Professional is a system design of printed circuit boards. Proteus Professional can simulate the following microcontrollers: 8051, ARM7, AVR, Motorola, PIC, Basic Stamp. The library contains the components of data Co-simulation of microprocessor software within a mixed mode SPICE simulator.

#### ARDUINO SOFTWARE

The Arduino Integrated Development Environment - or Arduino Software (IDE) - contains a text editor for writing code, a message area, a text console, a toolbar with buttons for common

functions and a series of menus. It connects to the Arduino and Genuino hardware to upload programs and communicate with them. Programs written using Arduino Software (IDE) are called sketches. The message area gives feedback while saving and exporting and also displays errors. The console displays text output by the Arduino Software (IDE), including complete error messages and other information. The bottom right hand corner of the window displays the configured board and serial port. The toolbar buttons allow you to verify and upload programs, create, open, and save sketches, and open the serial monitor.

## **CALCULATION OF UNDERGROUND CABLE RESISTANCE:**

The ac cable resistance can be calculated by using the constants, skin effect proximity effect

$$R_{ac} = R_{dc}(1 + Y_s + Y_p)$$

The dc cable resistance can be calculated by using the constants, resistivity temperature coefficient cross-sectional area

$$R_{dc} = \left( (1.02 \times 10^6 \cdot \rho) (1 + \alpha(\theta - 20)) \right) / s$$

### **SKIN EFFECT:**

The tendency of an ac current to become distributed within a conductor such that the current density is nearer the surface of the conductor and decreases with greater depth in the conductor.

### **PROXIMITY EFFECT:**

Proximity effect is the tendency for current to flow in other undesirable patterns-loops or concentrated distributions-due to the presence of magnetic fields generated by nearby conductors.

## **V.HARDWARE DESCRIPTION**

### **POWER SUPPLY UNIT**

Power supply is a very important part of electronic circuit. This circuit requires fixed +5 V supply so to fix this voltage we need voltage regulator. In this work we used IC7805 as voltage regulator. A voltage regulator generates a fixed output voltage of a preset magnitude that remains constant regardless of changes to its input voltage or load conditions. There are two types of voltage regulators: linear and switching. Here we make use of a linear regulator employs an active pass device (series or shunt) controlled by a high gain differential amplifier. It compares the output voltage with a passive reference voltage with a precise reference voltage and adjusts the pass device to maintain a constant output voltage.

### **LCD DISPLAY**

Liquid Crystal Display (LCD) is an Alphabetic Display it means that it can display Alphabets, Numbers as well as special symbols thus LCD is a user friendly Display device which can be used for displaying various messages unlike seven segment display which can display only numbers and some of the alphabets. The only disadvantage of LCD over seven segment display is that seven segment is robust display and can be visualized from a longer distance as compared to LCD. Here we have used 16 x 2 alphanumeric displays.

## **RELAY**

A relay is an electrically operated switch. Many relays use an electromagnet to mechanically operate a switch, but other operating principles are also used, such as solid-state relays. Relays are used where it is necessary to control a circuit by a separate low-power signal, or where several circuits must be controlled by one signal. The first relays were used in long distance telegraph circuits as amplifiers: they repeated the signal coming in from one circuit and re-transmitted it on another circuit. Relays were used extensively in telephone exchanges and early computers to perform logical operations. A type of relay that can handle the high power required to directly control an electric motor or other loads is called a contractor. Solid-state relays control power circuits with no moving parts, instead using a semiconductor device to perform switching. Relays with calibrated operating characteristics and sometimes multiple operating coils are used to protect electrical circuits from overload or faults; in modern electric power systems these functions are performed by digital instruments still called "protective relays".

## **BUZZER**

A **buzzer** or **beeper** is an audio signaling device, which may be mechanical, electromechanical, or piezoelectric. Typical uses of buzzers and beepers include alarm devices, timers, and confirmation of user input such as mouse click or keystroke.

## **VI.RESULT AND DISCUSSION**

Underground cables offer an affordable and justifiable solution for critical parts and in some cases the entire length of overhead high voltage power lines. With appropriate technology used in appropriate places, the environmental impact of underground cables can be minimized.

## **VII.CONCLUSION**

This project is intended to detect the exact location of circuit fault in the underground cables from the feeder end in km by using an arduino microcontroller. The arduino microcontroller works based on the output of the cable resistance. Relay helps to separate the faulty line from healthy line.

## **VIII.FUTURE SCOPE**

The project detects only the location of the circuit fault in underground cable line, but it can also be extended to detect the location of an open circuit fault. To detect an open circuit fault, capacitor is used in ac circuits which measures the change in impedance and calculate the distance of the fault.

## **IX.REFERENCES**

- [1]. Raghu Raja Kalia, Preeti Abrol, 'Design and implementation of wireless live wire fault detector and protection in remote areas', IEEE,(2014),vol. 97,No.17
- [2]. B. Clegg, Underground Cable Fault Location. New York: McGraw-Hill, 1993.

- [3]. M.-S. Choi, D.-S. Lee, and X. Yang, "A line to ground fault location algorithm for underground cable system," *KIEE Trans. Power Eng.*, pp. 267–273, Jun. 2005.
- [4]. E. C. Bascom, "Computerized underground cable faultlocation expertise," in *Proc. IEEE Power Eng. Soc. General Meeting*, Apr. 10–15, 1994, pp. 376–382. J. Clerk Maxwell, *A Treatise on Electricity and Magnetism*, 3rd ed., vol. 2. Oxford: Clarendon, 1892, pp. 68–73.
- [5]. K. K. Kuan, Prof. K. Warwick, "Real-time expert system for fault location on high voltage underground distribution cables", *IEEE PROCEEDINGS-C*, Vol. 139, No. 3, MAY 1992.
- [6]. Tarlochan S. Sidhu, Zhihan Xu, "Detection of Incipient Faults in Distribution Underground Cables", *IEEE Transactions on Power Delivery*, Vol. 25, NO. 3, JULY 2010.
- [7]. J. Densley, "Ageing mechanisms and diagnostics for power cables—an overview," *IEEE Electr. Insul. Mag.*, vol. 17, no. 1, pp. 14–22, Jan./Feb. 2001.
- [8]. T. S. Sidhu and Z. Xu, "Detection of incipient faults in distribution underground cables", *IEEE Trans. Power Del.*, vol. 25, no. 3, pp. 1363–1371, Jul. 2010.